

## 製品仕様書

製品名称 : NP型支持脚

### 目次

1. 製品仕様
2. 製品形状図
3. 適応床高
4. 梱包仕様

泰成 株式会社

〒399-4102 長野県駒ヶ根市飯坂2-8-34

## 1. 製品仕様

### 1-1.支持脚

#### ①台座

項目	仕様・品質
ブロック部材質	JIS A 5908 (パーティクルボード) 18MR1 (M) または 18MR2 (P) F☆☆☆☆
粘着テープ材質	両面粘着テープ ブチルゴム系またはアクリル系
ナット部材質	JIS G 3131 (熱間圧延軟鋼板及び鋼帯) SPHC または JIS G 3507-1 (冷間圧造用炭素鋼-第1部:線材) SWRCH10R (相当) または JIS G 3507-2 (冷間圧造用炭素鋼-第2部:線) SWCH10R (相当) または JIS G 3505 (軟鋼線材) SWRM6 (相当) または SWRCH10R (相当)
ナット部表面処理	JIS H 8610 (電気亜鉛めっき) 3級
寸法	2. 製品形状図参照
外観	ネジ部にキズのないこと
	めっき剥離のないこと
かしめトルク	14N・m 以上であること
その他	使用上支障のないこと

#### ②支持ボルト

項目	仕様・品質
ボルト部材質	JIS G 3445 (機械構造用炭素鋼鋼管) STKM11A (相当) または STKM12C (相当) または 溶融めっき鋼帯 (ZAM) STKM11A (相当)
ボルト部表面処理※	JIS H 8610 (電気亜鉛めっき) 3級
防振ゴム部材質	JIS K 6386 (防振ゴム-ゴム材料の区分) A種 硬さ 70 ± 5°
寸法	2. 製品形状図参照
外観	ネジ部にキズのないこと
	めっき剥離のないこと
その他	使用上支障のないこと

※溶融めっき鋼帯は表面処理済。

### 1-2.接着剤

項目	仕様・品質
材質	ポリウレタン系
寸法	400ml または 200ml
その他	シアン化合物、有機リン化合物、ヒ素及びその化合物、ホルムアルデヒド、水質汚濁防止法に係る重金属類、PCB、フェノール等の物質、トルエン、キシレン及び木材保存剤、可塑剤、防蟻剤は使用していない。

## 2. 製品形状図

### 2-1. 支持脚

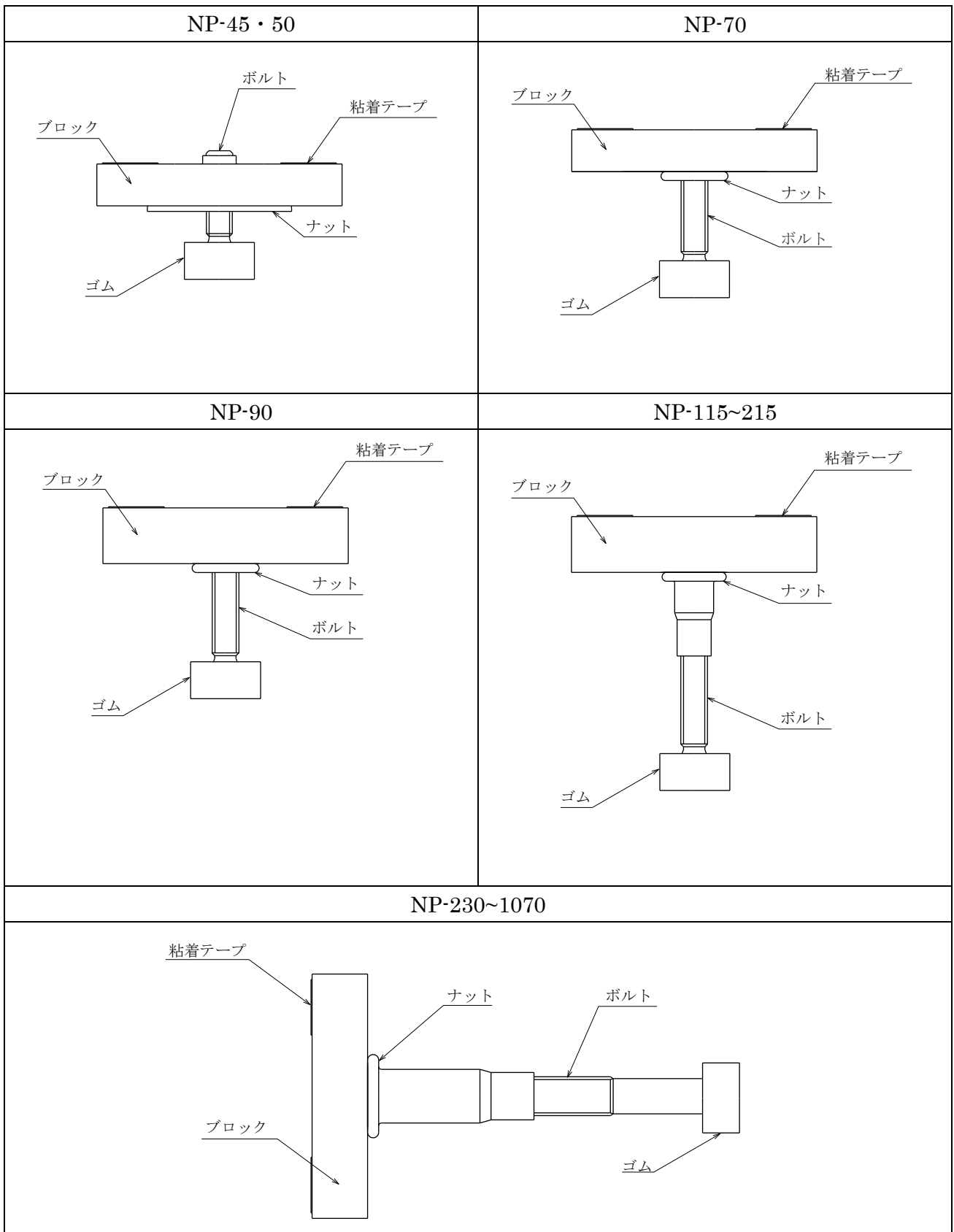

2-2.台座

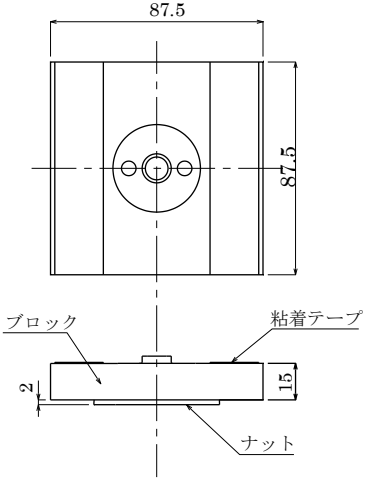
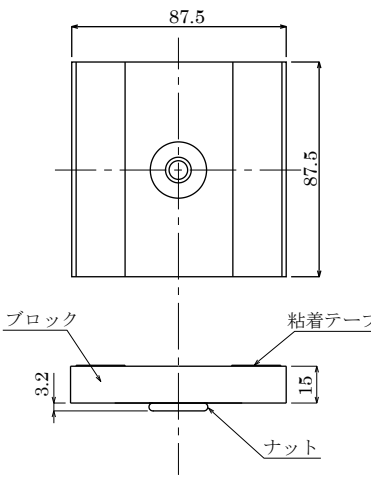
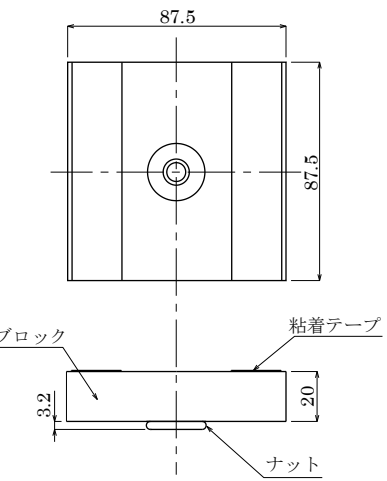
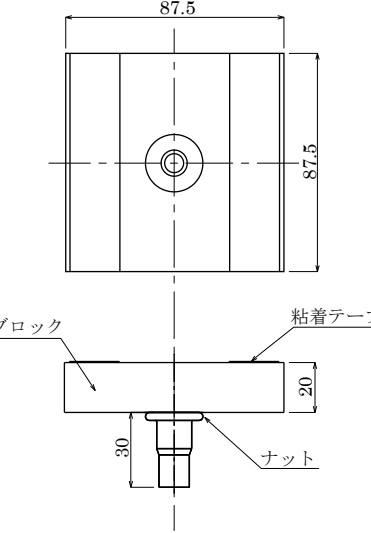
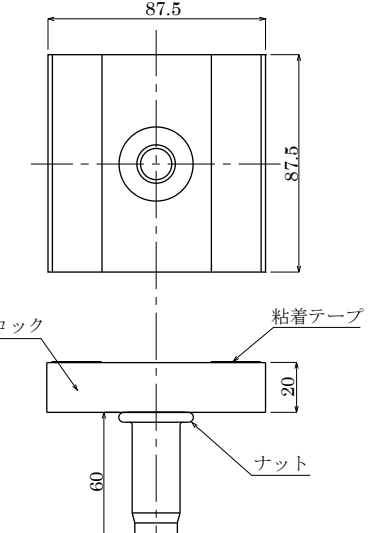
NP-45・50	NP-70	NP-90
 <p>Technical drawing for NP-45・50. The top view shows a square with side length 87.5. The side view shows a block with a height of 2, a width of 15, and labels for 'ブロック', '粘着テープ', and 'ナット'.</p>	 <p>Technical drawing for NP-70. The top view shows a square with side length 87.5. The side view shows a block with a height of 3.2, a width of 15, and labels for 'ブロック', '粘着テープ', and 'ナット'.</p>	 <p>Technical drawing for NP-90. The top view shows a square with side length 87.5. The side view shows a block with a height of 3.2, a width of 20, and labels for 'ブロック', '粘着テープ', and 'ナット'.</p>
NP-115~215	NP-230~1070	
 <p>Technical drawing for NP-115~215. The top view shows a square with side length 87.5. The side view shows a block with a height of 20 and a distance of 30 from the bottom edge to the nut, with labels for 'ブロック', '粘着テープ', and 'ナット'.</p>	 <p>Technical drawing for NP-230~1070. The top view shows a square with side length 87.5. The side view shows a block with a height of 20 and a distance of 60 from the bottom edge to the nut, with labels for 'ブロック', '粘着テープ', and 'ナット'.</p>	

### 2-3.支持ボルト

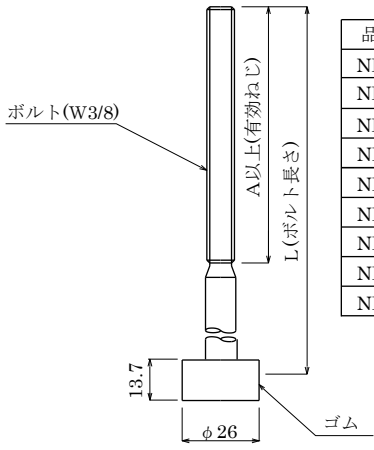
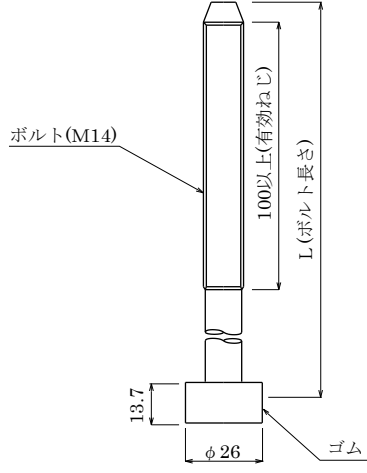
NP-45~215	NP-230~1070																																																														
 <table border="1" style="margin-left: auto; margin-right: auto; border-collapse: collapse; text-align: center;"> <thead> <tr> <th>品番</th> <th>L</th> <th>A</th> </tr> </thead> <tbody> <tr><td>NP-45</td><td>30</td><td>18.5</td></tr> <tr><td>NP-50</td><td>40</td><td>28.5</td></tr> <tr><td>NP-70</td><td>50</td><td>38.5</td></tr> <tr><td>NP-90</td><td>60</td><td>48.5</td></tr> <tr><td>NP-115</td><td>60</td><td>48.5</td></tr> <tr><td>NP-125</td><td>90</td><td>78.5</td></tr> <tr><td>NP-155</td><td>120</td><td>87.0</td></tr> <tr><td>NP-185</td><td>150</td><td>87.0</td></tr> <tr><td>NP-215</td><td>180</td><td>87.0</td></tr> </tbody> </table>	品番	L	A	NP-45	30	18.5	NP-50	40	28.5	NP-70	50	38.5	NP-90	60	48.5	NP-115	60	48.5	NP-125	90	78.5	NP-155	120	87.0	NP-185	150	87.0	NP-215	180	87.0	 <table border="1" style="margin-left: auto; margin-right: auto; border-collapse: collapse; text-align: center;"> <thead> <tr> <th>品番</th> <th>L</th> </tr> </thead> <tbody> <tr><td>NP-230</td><td>185</td></tr> <tr><td>NP-290</td><td>245</td></tr> <tr><td>NP-350</td><td>305</td></tr> <tr><td>NP-410</td><td>365</td></tr> <tr><td>NP-470</td><td>425</td></tr> <tr><td>NP-530</td><td>485</td></tr> <tr><td>NP-590</td><td>545</td></tr> <tr><td>NP-650</td><td>605</td></tr> <tr><td>NP-710</td><td>665</td></tr> <tr><td>NP-770</td><td>725</td></tr> <tr><td>NP-830</td><td>785</td></tr> <tr><td>NP-890</td><td>845</td></tr> <tr><td>NP-950</td><td>905</td></tr> <tr><td>NP-1010</td><td>965</td></tr> <tr><td>NP-1070</td><td>1025</td></tr> </tbody> </table>	品番	L	NP-230	185	NP-290	245	NP-350	305	NP-410	365	NP-470	425	NP-530	485	NP-590	545	NP-650	605	NP-710	665	NP-770	725	NP-830	785	NP-890	845	NP-950	905	NP-1010	965	NP-1070	1025
品番	L	A																																																													
NP-45	30	18.5																																																													
NP-50	40	28.5																																																													
NP-70	50	38.5																																																													
NP-90	60	48.5																																																													
NP-115	60	48.5																																																													
NP-125	90	78.5																																																													
NP-155	120	87.0																																																													
NP-185	150	87.0																																																													
NP-215	180	87.0																																																													
品番	L																																																														
NP-230	185																																																														
NP-290	245																																																														
NP-350	305																																																														
NP-410	365																																																														
NP-470	425																																																														
NP-530	485																																																														
NP-590	545																																																														
NP-650	605																																																														
NP-710	665																																																														
NP-770	725																																																														
NP-830	785																																																														
NP-890	845																																																														
NP-950	905																																																														
NP-1010	965																																																														
NP-1070	1025																																																														

### 3. 適応床高（床パネル厚20mm時の床パネル天端までの高さ）

品番	適応床高(mm)
NP- 45	43 ~ 54
NP- 50	49 ~ 64
NP- 70	59 ~ 90
NP- 90	69 ~ 105
NP- 115	90 ~ 132
NP- 125	99 ~ 162
NP- 155	129 ~ 192
NP- 185	159 ~ 222
NP- 215	189 ~ 252
NP- 230	195 ~ 280
NP- 290	255 ~ 340
NP- 350	315 ~ 400
NP- 410	375 ~ 460
NP- 470	435 ~ 520
NP- 530	495 ~ 580
NP- 590	555 ~ 640
NP- 650	615 ~ 700
NP- 710	675 ~ 760
NP- 770	735 ~ 820
NP- 830	795 ~ 880
NP- 890	855 ~ 940
NP- 950	915 ~ 1000
NP-1010	975 ~ 1060
NP-1070	1035 ~ 1120

## 4. 梱包仕様

### 4-1. 梱包外観

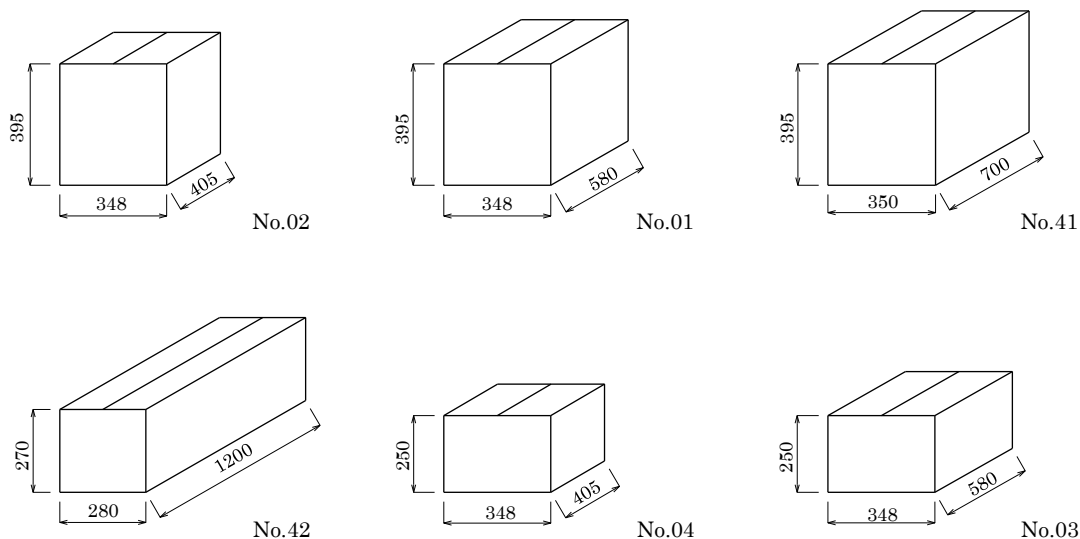

### 4-2. 梱包重量

品番	梱包重量(kg/箱)	入数	梱包箱(mm)
NP- 45	16.7	100セット	No.02 405×348×395
NP- 50	17.0		
NP- 70	14.7		
NP- 90	18.5	80セット	No.01 580×348×395
NP- 115	16.1		
NP- 125	16.9		
NP- 155	18.0		
NP- 185	19.2		
NP- 215	13.2	50セット	
NP- 230	17.3		
NP- 290	19.1	40セット	
NP- 350	16.8		
NP- 410	18.3		
NP- 470	19.7	30セット	No.41 700×350×395
NP- 530	16.4		
NP- 590	17.5		
NP- 650	18.5	20セット	No.42 1200×280×270
NP- 710	13.8		
NP- 770	14.5		
NP- 830	15.2		
NP- 890	15.9		
NP- 950	16.6		
NP-1010	17.3		
NP-1070	18.0		

品番	梱包重量(kg/箱)	入数	梱包箱(mm)
NP-45h	8.9	50 セット	No.04 405×348×250
NP-50h	9.0		
NP-70h	7.9		
NP-90h	9.9	40セット	No.03 580×348×250
NP-115h	8.7		
NP-125h	9.1		
NP-155h	9.7		
NP-185h	10.3		
NP-215h	7.4	25セット	
NP-230h	9.3		
NP-290h	10.2		
NP-350h	9.2	20 セット	
NP-410h	9.9		
NP-470h	10.6		

仕様は予告なく変更することがあります。